

CHEAP CONTROLS MZTIMER

User Guide

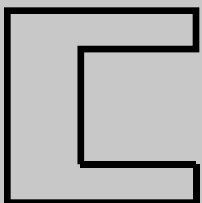

copyright © 2005-2007 Cheap Controls LLC all rights reserved

Important Safety Instructions

1. Read these instructions completely before installing and using the equipment.
2. Keep these instructions in a safe place.
3. Pay attention to all warnings.
4. Follow all the instructions.
5. In order to reduce the risk of fire or electric shock, do not expose this apparatus to rain or moisture.
6. Clean with a soft, dry cloth. If further cleaning of the switch plate is required remove from switch prior to applying moisture.
7. Refer all servicing to qualified service personnel. Service is required when the unit has been damaged in any way, such as: liquid is spilled onto the device, the device is exposed to rain, or if the unit does not operate normally.

Warranty

Due to the custom nature and/or possible uses of this product, Cheap Controls LLC makes no warranty, promise or representation not expressly set forth herein. Except as expressly warranted herein, the product is provided “as is” without warranty of any kind. Cheap Controls LLC disclaims and excludes all implied warranties including, without limitation, the implied warranties of noninfringement, merchantability and fitness for a particular purpose. Cheap Controls LLC does not warrant the the product will satisfy customer’s requirements or that it is without defect or error that the operation thereof will be uninterrupted. This agreement gives the customer specific legal rights. The customer may have other rights, which vary from jurisdiction to jurisdiction.

Notice of Caution and Liability

Only experienced persons should install this equipment. Improper installation may result in damage to this switch along with damage to the equipment it is intended to control. Cheap Controls LLC assumes no responsibility for improper installation of this equipment.

Getting Started

Introduction

This device was developed to control an air solenoid on for a CNC coolant system. Eight different buttons can be programmed with individual on and off times. The times are programmed in seconds ranging from 0 to 255.

Package Includes

1. MZTIMER main board.
2. MZRELAY board
3. Relay connection cable
2. Power supply.
3. Rubber button inlay.
4. Cover plate.
5. Communication cable.
6. MZTimer installation CD.

Installation

1. Installing MZTimer on your PC.

Method 1: Installing from CD

- 1.1 Load the MZTimer Installation CD into your CD drive.
- 1.2 Go to your start menu and select RUN and enter D:\setup.exe where D: is the drive letter for your cd drive.
- 1.3 Follow the MZTimer Installation Wizard to install software.
- 1.4 Launch MZTimer.

Method 2: Downloading from Cheap Controls LLC

- 1.1 Go to www.cheapcontrols.com and download from the **Timer** page.
- 1.2 Save the downloaded file to your desktop.
- 1.3 Create a temporary folder on your desktop. (this folder can be deleted after installation)
- 1.4 Unzip the downloaded file into the folder you just created.
- 1.5 Open the folder and run **setup.exe**.
- 1.6 Follow the MZTimer Installation Wizard to install software.
- 1.7 Launch MZTimer.

2. Connecting the MZTimer to your PC. (see fig. 1 below)

2.1 Connect the power supply to the MZTimer.

There should be a label on the power supply cord that shows the connection location.

2.2 Connect the communication cable to the MZTimer.

There should be a label on the comm cable that shows the connection location.

The connection on the switch is labeled.

GND Ground

1 RS232 input signal from the PC.

2 RS232 output signal to the PC.

2.3 Plug the power supply into an AC outlet.

2.4 Connect the communication cable to an open 9 pin serial port on your PC.

The MZRS232 is now ready for programming.

3. Connecting the MZRelay board to the MZTimer. (see fig. 2 below)

3.1 locate the six pin header on the main MZTimer board.

3.2 There should be a cap over the connector that should be removed.

3.3 Connect the the relay cable to the header connection.

WARNING: It is possible to force this connector on backwards, damage may result.

3.4 Connect the other end to the relay board.

There should be a label on the cable that shows the connection location.

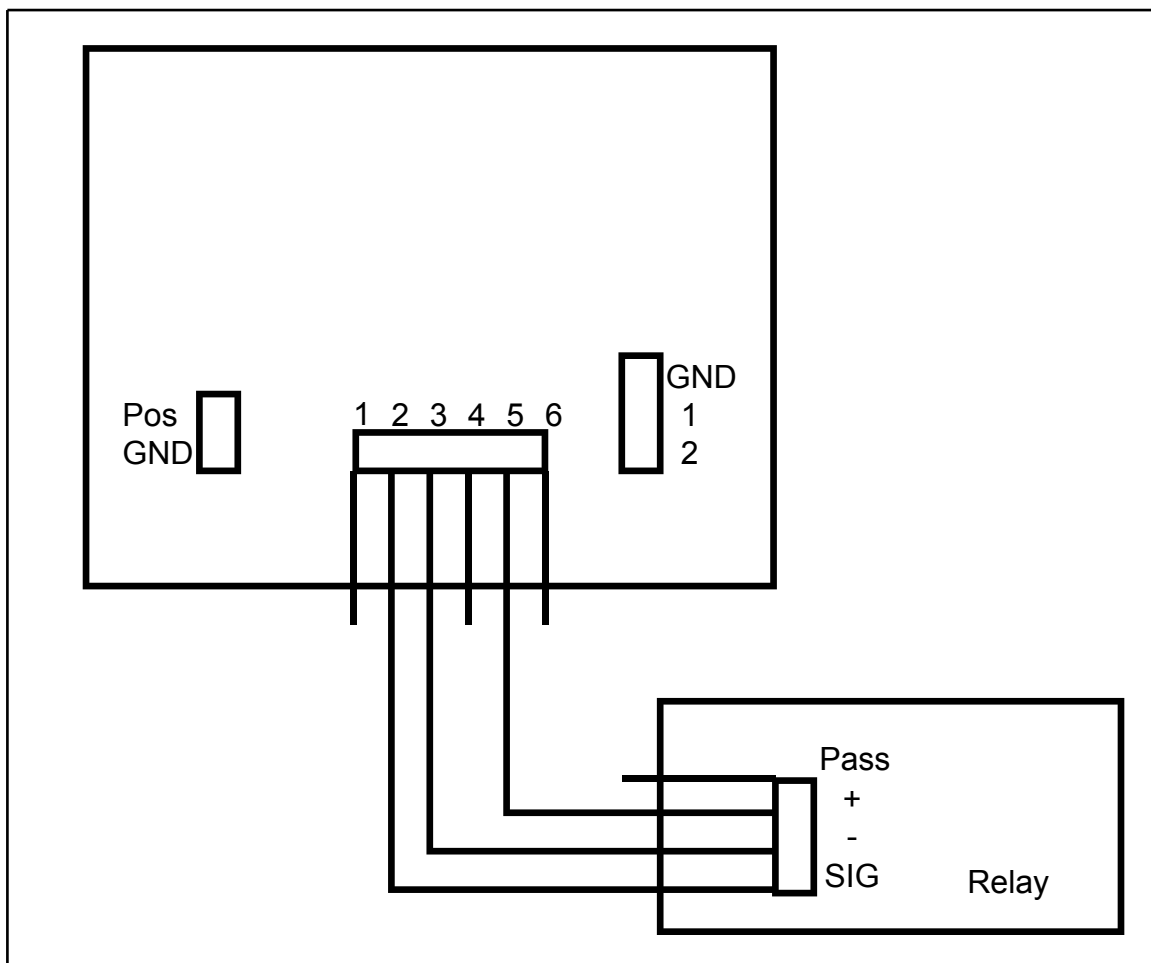

Fig. 1

4. Programming the MZTimer (see fig. 2 below)

- 4.1 Select the proper **Communication Port** from the available options. (default is Comm 1)
- 4.2 Click **Connect**; an alert box should notify you of a connection failure.
- 4.3 Click **Read Data From Switch** to collect any information currently in the MZTimer.
(data should appear if the timer is physically connected after step 3.2)
- 4.4 Click **Load Values from switch into write field** if you want to quickly copy all the data from the switch into the editable fields.
- 4.5 Click **Send Data To Switch** in order to load the switch.

Note: The data in the fields directly below the **ON** and **OFF** labels is the data sent to the Timer.

TIP If you only want to edit one switch use the **Load Values from switch into write field** to save time instead of retyping the old settings.

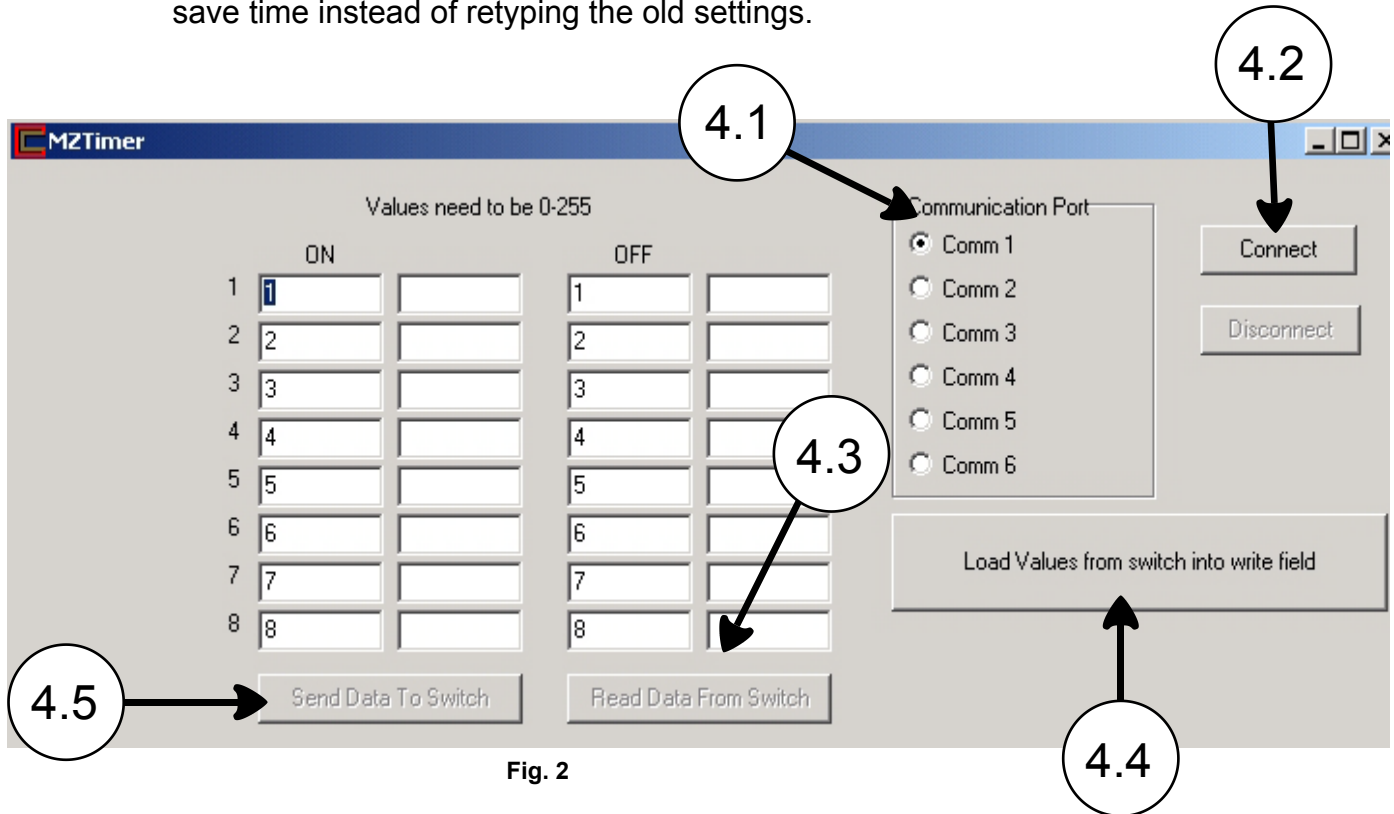

Fig. 2

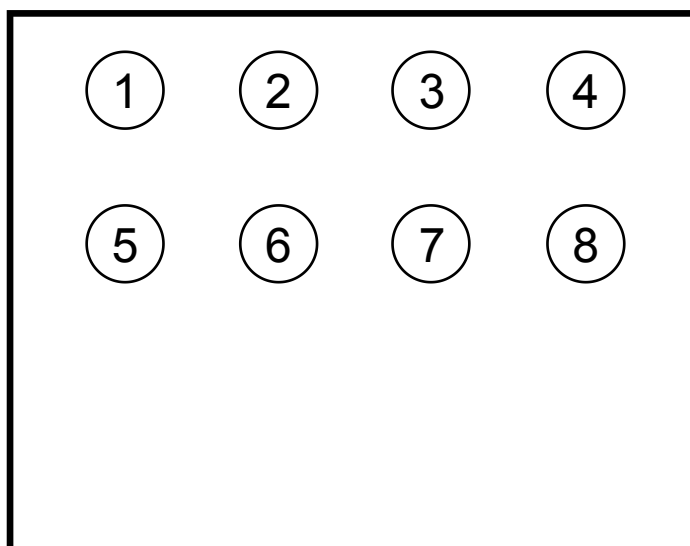

Fig. 3

Figure 3 on the left is a layout that shows the relationship between the physical timer and the programming software.

Troubleshooting

No Power

1. Make sure the power cable is connected with the correct polarity.
2. There are diodes to protect the board in case of incorrect power connection.

No Communication with Programming PC

1. Make sure the cable is connected correctly at the MZTimer board
2. Make sure the correct port is selected on the PC.

I give up!

1. If you are still having difficulty email info@cheapcontrols.com .

Simple Wiring Diagram

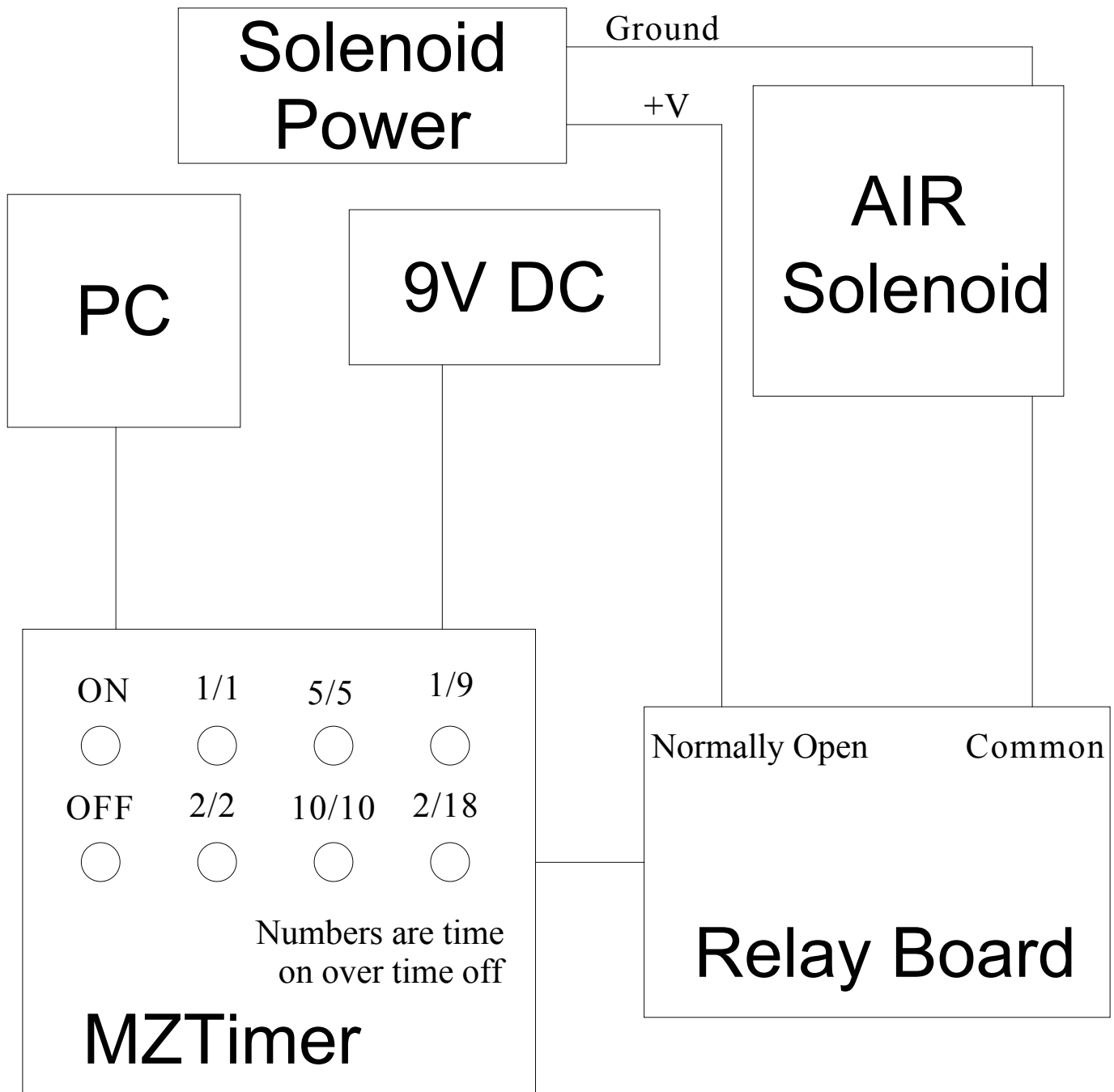

This is an example setup for controlling a 12 volt solenoid supplying cooling air to a CNC machine.